

PF-Underseat-12-250H

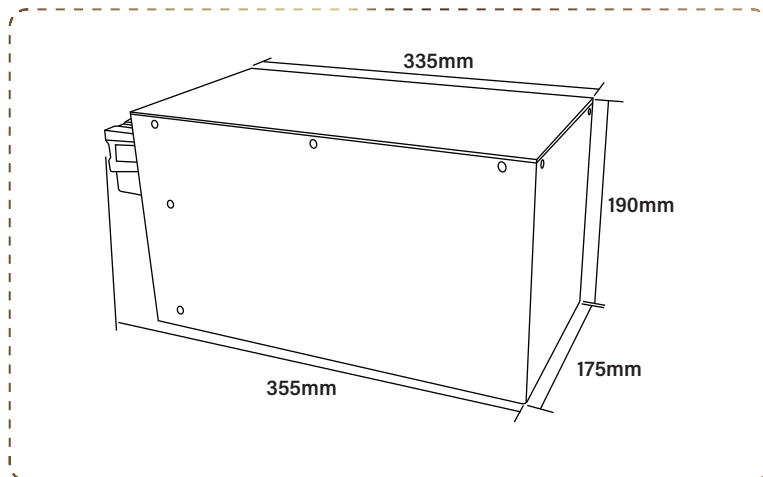

LITHIUM BATTERY

Strong Advantages

- 6 Years Warranty
- Replacement of lead-acid battery
- Lighter weight and easier to handle
- Lithium iron phosphate is more stable
- Maximum service life of over 6000 cycles
- Long-lasting modular construction
- Screw opening, perfect crafted internal structure design

ELECTRIC HEATING FILM

- Some of the Perfektium lithium batteries are equipped with heating films. You can use the battery in temperatures as low as -35 degrees Celsius when acting the heating films
- The heating film is an IP material and the heating effect is even
- The heating films do not consume any power from the battery itself

BMS

Battery Management System

The BMS monitors and controls the individual cells of each battery and protects them from damage, such as overload

BLUETOOTH 4.0 INTEGRATED

Multiple Battery Monitoring Function

Perfektium Pro APP can monitor up to 8 batteries at the same time. The SOC, voltage, current, temperature, available time of the batteries can be detective.



Specification

Items	Characteristics
Model	12.8V 250Ah/3200Wh
Replaces Gel-AGM battery	12.8V 500Ah
Cell type	Prismatic cell
Dimensions (L × W × H)	335×175×190 mm (355 mm incl. terminals)
Weight (No Accessories)	23,8kg
Cycle Life	>6000@80%D.o.D
Internal Resistance	≤7mΩ
Recommended Charge Voltage	14.6V
Float Charge Voltage (For standby use)	13.8±0.8V
Recommended Charge Current	40A
Max Charge Current	200A
Continuous Discharge Current	200A
Peak Discharge Cut-Off Current	600A (200~500ms)
Operating Voltage Range	10 - 14.6V
End of Discharge Voltage Range	10 - 11.2V
Terminal Type	M8
Ingress Protection Code	IP62
Charge Temperature	0~50°C
Discharge Temperature	-20~75°C
Storage Temperature	-5~35°C
Heater Operating Temperature	-35~5°C
Storage Condition	Charging the battery every 3 months
Series & Parallel Availability	Maximum 4 pcs in series and 4 pcs in parallel
Certifications	CE/UL/UN38.3/MSDS/ROHS/UN 3480/CLASS9/ECE R10